



INSTALLATION MANUAL FOR ORIFICE PLATE

DELTA ENGINEERING

Office

10 Krishnakunj, 3rd floor, 1187/23 Ghole Road,
Shivajinagar, Above Andhra Bank, Pune 411 005

Telefax - +91-20-25520163/66027716

Email: deltaeng@eth.net

www.orificenozzleventuri.com

Factory

W-22 MIDC Baramati, Taluka – Baramati,
District – Pune 413133 Telefax – +91-2112-243362

Email: ajay@deltaeng.co.in

CONTENTS

1. Orifice Plate Installation
2. Integral Orifice plate Installation
3. Location and mounting of Differential Pressure Transmitter
4. Three valve manifold type and mounting
5. Impulse piping
6. Impulse piping for different fluid service
7. System commissioning

ORIFICE PLATE ASSEMBLY

The orifice plate designed as per ISO 5167 or Equivalent Standard is supplied along with a set of flanges, gaskets, studs, nuts & plugs. Two pairs of flange tapings are generally ½” NPT (F). The flanges are to be welded in the pipeline with sufficient upstream and downstream lengths and properly bolted.

PRECAUTIONS FOR ORIFICE PLATE INSTALLATION

1. Determine the location & orientation. Sufficient upstream and downstream straight length of pipe must be kept without any restriction like valves, bypass arrangement, thermo-well pockets etc. to get a fully developed flow profile which helps in obtaining the published accuracy per standard. Refer the Annexure for straight length requirements.
2. Depressurize the line using site-specific requirements.
3. Loosen all studs and nuts. Remove the studs in one-half of the flange union and spread flange union by turning jackscrews clockwise.
4. Install the Orifice plate with the face marked “INLET” on the tag towards upstream.
5. The orifice plate must be installed concentric with the pipe ID.
6. Install the new gaskets when installing the plate. It is recommended that new gaskets be installed each time the orifice flange union is separated.
7. Release the flange union by turning the jackscrews counter-clockwise.
8. Replace the studs & tighten nuts in a star pattern.
9. One pair of tapping must be plugged or closed with an isolation valve.

INTEGRAL ORIFICE PLATE ASSEMBLY

The integral orifice plate assembly designed as per ISO 5167 or Equivalent Standard is supplied along with a set of integral flanges, gaskets, studs, nuts & meter run pipe with end flanges. An “H” type three valve manifold is required. No impulse tubing.

PRECAUTIONS FOR INTEGRAL ORIFICE PLATE INSTALLATION

1. Determine the location & orientation. Sufficient upstream and downstream straight length of pipe must be kept without any restriction like valves, bypass arrangement, thermo-well pockets etc. to get a fully developed flow profile which helps in obtaining the published accuracy per standard. Refer the Annexure for straight length requirements.
2. Depressurize the line using site-specific requirements.
3. Loosen all studs and nuts.
4. Install the Orifice plate with the face marked “INLET” on the tag towards upstream.
5. The orifice plate must be installed concentric with the pipe ID.
6. Install the new gaskets when installing the plate. It is recommended that new gaskets be installed each time the orifice flange union is separated.
7. Replace the studs.
8. Mount the “H” type manifold process side on the integral flange and tighten the bolt by properly installing the O-ring gasket.
9. Mount the DP transmitter on the “H” type manifold.

LOCATION AND MOUNTING OF DIFFERENTIAL PRESSURE TRANSMITTER

The Transmitter should be located in such a way that it is easily approachable for maintenance and frequent checks. The distance between pressure tapping on the process line and the Transmitter should be as short as possible. The site should be free from excessive vibrations. The ambient temperature around Transmitter should not exceed 100 °C. The Transmitter should be so mounted that features like self drain, self vent, site adjustable span and zero features can be effectively and easily utilized.

The Transmitter is mounted on a 50 NB pipe using a mounting bracket supplied by the Transmitter manufacturer. The Transmitter can be mounted on either a horizontal or vertical pipe.

- If the process fluid is a gas, then as a rule the Transmitter must be located higher than the process pressure taps.
- If the process fluid is a liquid or steam, then as a rule the Transmitter must be located lower than the process pressure taps.

THREE VALVE MANIFOLD

The manifold can be mounted directly on the Transmitter. ½" NPT (F) process connections are provided.

THREE VALVE MANIFOLD MOUNTING PROCEDURE

1. Remove the process connectors and the process connector gaskets from the Transmitter.
2. Ensure that the Ring gaskets with the three-valve manifold are sufficiently thick to provide compression sealing.
3. Mount the flanged side of the manifold on the Transmitter with the Hex bolts supplied with the manifold (7/16"UNF x 1" long).
4. Tighten the Hex bolts equally until required sealing is achieved.
5. After completing the connection of the Transmitter and 3-valve manifold, be sure to close the low pressure and high pressure stop valves, open the equalizing valve, and leave the manifold with equalizing valve open.

IMPULSE PIPING

Piping procedure of impulse piping depend on the type of process fluid and location of Transmitter. There should be no leakage and clogging in the impulse piping. The impulse pipe should be of ½". Three-piece unions should be incorporated in the impulse piping to provide easy maintenance. The length of impulse piping should be as short as possible.

For Gas flow measurement the impulse pipe length should not be more than 15 meter and for steam or liquid flow measurement the length should net be more than 30 meter.

The impulse piping must be routed with only an upward or downward slope. Even for horizontal routing, the impulse piping should have a slope of at least 1/10 to prevent condensate (or gases) from stagnating in the pipes.

Impulse piping should be clamped at a desired span to prevent pipe from vibrating. Drain valves should be provided for flushing and removal of air pockets. The take-outs should be symmetrical. Parallel take-outs are also possible where space is a problem.

If there is a temperature difference between the high and low impulse piping, the density difference of the fluids in the two lines will cause an error in the measurement pressure. When measuring flow, the impulse piping must be routed together so that there is no temperature difference between them.

LIQUID FLOW MEASUREMENT

The pressure taps must be horizontal or below horizontal but not more than 45⁰ below horizontal as shown in the drawing. This prevents air pocket formation and reduces the chances of clogging of the impulse pipe due to deposits from the process fluid. Flushing arrangement with drain valves should be provided.

It is recommended that the Transmitter be installed below the primary element. For corrosive liquids seal pots should be provided before the Transmitter, which contains the sealing liquid to separate the process fluid from and to conduct the pressure to the Transmitter.

STEAM FLOW MEASUREMENT

The pressure taps must be horizontal or above horizontal, but not more than 45⁰ above horizontal as shown in the drawing. The Transmitter should be installed below the primary element.

Condensate pots are used to obtain larger surface area to form condensate. The condensate pots are mounted horizontally and must be in level. This will avoid any zero shift created in condensate head. Draining arrangement of condensate should be provided with drain valves.

GAS FLOW MEASUREMENT

The pressure taps must be vertical or within 45⁰ either side of vertical. The Transmitter should be installed at the upper elevation than the primary element. This prevents condensate collecting in the impulse piping. In case of corrosive gas, seal pots may be used before Transmitter.

WIRING / LOOP DIAGRAM

The external wiring terminals of the Transmitter are on the field terminal side of the electrical housing (indicated on the label)

The terminals are:

1. A pair of terminal for supply and signal output.
2. A pair of test terminal.
3. 1 terminal for case ground.

The test terminals are provided for connecting the indicating meter or for checking the Transmitter current output signal with an ammeter.

The two-wire Transmitter requires only a single 2 core cable which carries both the 24 V DC power supply necessary to energize the Transmitter and the 4 to 20 mA output signal.

PVC insulated two-core 0.75 to 1.5 mm² armored cable for industrial application should be used for the connection between the Transmitter and the flow indicator. The cable should enter the Transmitter through the conduit opening provided on the housing.

A ½" NPT gland nut with rubber grommet will ensure proper weather-proofing of the enclosure. Alternatively a rubberized sealing compound may be used to prevent water from entering the system.

SYSTEM COMMISSIONING

- A. Prior to commissioning the system, check the following:
1. No leakages in impulse piping.
 2. Proper termination of the LP and HP pipes to the Transmitter.
 3. Location of orifice plate tapping.
 4. Routing of impulse lines.
 5. Proper termination of cables at both Transmitter and instrument ends.
- B. Procedure for commissioning.
1. Check 24 V DC supply to Transmitter.
 2. Open both drain plugs of Transmitter to atmosphere.
 3. Output at test terminals should be 4 mA. If not, adjust zero point accessible externally on the body of electronic housing.
 4. Keep all the three valves of manifold shut.
 5. Open isolating valves of both the HP and LP lines and flush the system by opening the drain stop valves.
 6. For steam service:
After flushing the lines with steam shut both the isolating valves and the drain valves. Open all the valves of the valve manifold. Unscrew the plugs of both the condensate pots and fill the impulse lines with water. Put on the plugs of condensate pots.
 7. Close the LP and HP valves of the manifold but keep the equalizing valve open.
 8. Open both the isolating valves.
 9. Ensure that the equalizing valve is open. Slowly open the LP valve. Let the pressure equalize in the Transmitter. Open the HP valve of the manifold.
 10. Open slightly the drain plus on the Transmitter and drain the condensate to remove any air pockets in the impulse lines. Re-tighten the drain plugs.
 11. Shut the equalizing valve.
 12. Check the output of Transmitter.



Required Straight Lengths between Orifice plates and Fittings without flow conditioners as per ISO 5167-2:2003

Values Expressed as multiples of internal diameter D

Diameter ratio β^a	Upstream (inlet) side of Orifice plates																						Downstream (outlet) side of the Orifice plate			
	Single 90° bend Two 90° bends in any plane (S > 30D) ^a	Two 90° bends in the same plane: S-configuration (30D ≥ S > 10D) ^a	Two 90° bends in the same plane: S-configuration (10D ≥ S) ^a	Two 90° bends in perpendicular plane (30D ≥ S ≥ 5D) ^a	Two 90° bends in perpendicular plane (5D > S) ^{a,b}	Single 90° tee with or without an extension Mitre 90° bend	Single 90° bends Two 45° bends in the same plane: S-configuration (S ≥ 2D) ^a	Concentric reducer 2D to D over a length of 1.5D to 3D	Concentric expander 0.5D to D over a length of D to 2D	Full bore ball or gate valve fully open	Abrupt symmetrical reduction	Thermometer pocket or well ^c of diameter between ≤ .03D ^d	Fittings (Columns 2 to 11) and the densitometer pocket													
1	2		3		4		5		6		7		8		9		10		11		12		13		14	
	A ^e	B ^f	A ^e	B ^f	A ^e	B ^f	A ^e	B ^f	A ^e	B ^f	A ^e	B ^f	A ^e	B ^f	A ^e	B ^f	A ^e	B ^f	A ^e	B ^f	A ^e	B ^f	A ^e	B ^f	A ^e	B ^f
≤0.20	6	3	10	g	10	g	19	18	34	17	3	g	7	g	5	g	6	g	12	6	30	15	5	3	4	2
0.40	16	3	10	g	10	g	44	18	50	25	9	3	30	9	5	g	12	8	12	6	30	15	5	3	6	3
0.50	22	9	18	10	22	10	44	18	75	34	19	9	30	18	8	18	20	9	12	6	30	15	5	3	6	3
0.60	42	13	30	18	42	18	44	18	65 ^h	25	29	18	30	18	9	18	26	11	14	7	30	15	5	3	7	3.5
0.67	44	20	44	18	44	20	44	20	60	18	36	18	44	18	12	18	28	14	18	9	30	15	5	3	7	3.5
0.75	44	20	44	18	44	22	44	20	75	18	44	18	44	18	13	18	36	18	24	12	30	15	5	3	8	4

NOTE 1 The minimum straight lengths required are the lengths between various fittings located upstream or downstream of orifice plate and orifice plate itself. Straight lengths shall be measured from downstream end of curved portion of nearest (or only) bend or of the tee or the downstream end of curved or conical portion of reducer or expander.

NOTE 2 Most of the bends on which the lengths in this table are based had a radius of curvature equal to 1.5D.

a S is the separation between the bends measured from downstream end of the curved portion of upstream end of the curved portion of down stream bend.

b This is not a good installation; a flow conditioner should be used where possible.

c The installation of thermometer pockets or wells will not alter the required minimum upstream lengths for the other fittings.

d A thermometer pocket or well of diameter between 0.03D to 0.13D may be installed provided that values in columns A and B are increased to 10 and 20 respectively. Such an installation is not, however, recommended.

e Column A for each fitting gives length corresponding to "zero additional uncertainty" values. (see 6.2.3)

f Column B for each fitting gives length corresponding to "0.5% additional uncertainty" values. (see 6.2.4)

g The straight length in column A gives zero additional uncertainty; data are not available for shorter straight lengths which could be used to give the required straight lengths for column B.

h 95D is required for $Re_D > 2 \times 10^6$ if $S < 2D$.

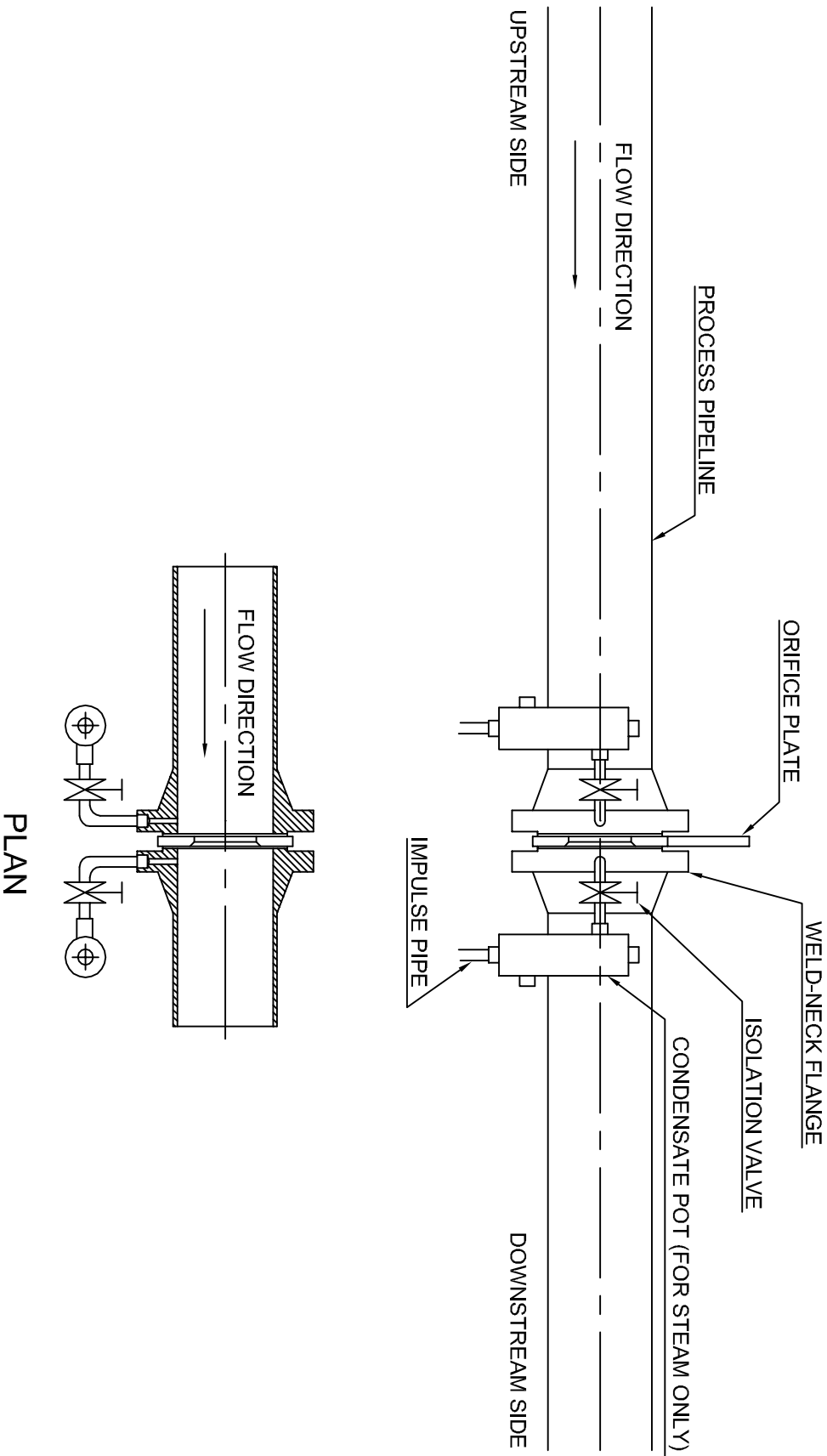

**WNRF ORIFICE PLATE ASSEMBLY
WITH FLANGE TAPPING**



DELTA ENGINEERING
10 Krishnakunj, 1187/23 Ghole Road, Shivajinagar, Pune 411005

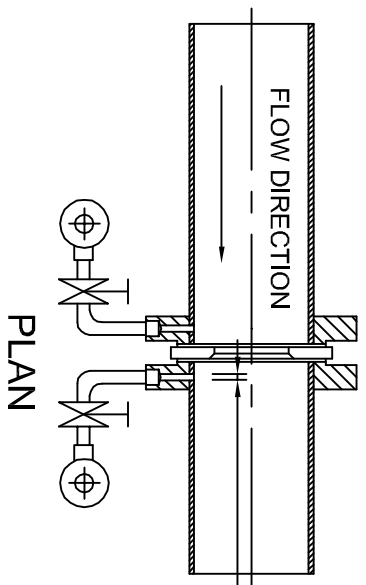
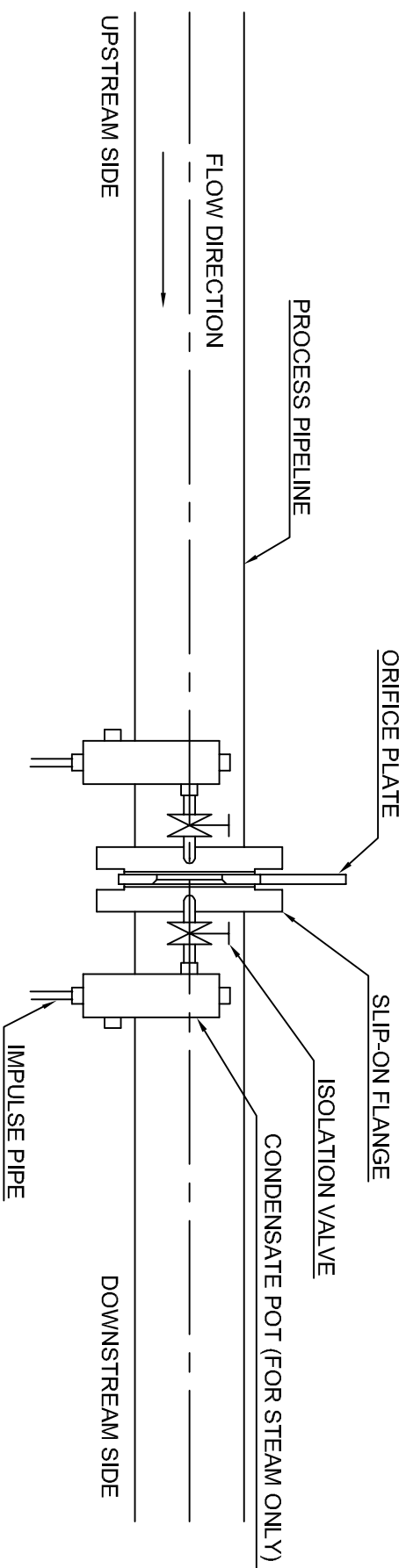

DRILL TWO HOLES IN THE PROCESS PIPE
EQUAL TO THE TAPPING HOLE SIZE ON THE FLANGE.

SORF ORIFICE PLATE ASSEMBLY WITH FLANGE TAPPING



DELTA ENGINEERING
10 Krishnakunj, 1187/23 Ghole Road, Shivajinagar, Pune 411005

GAS

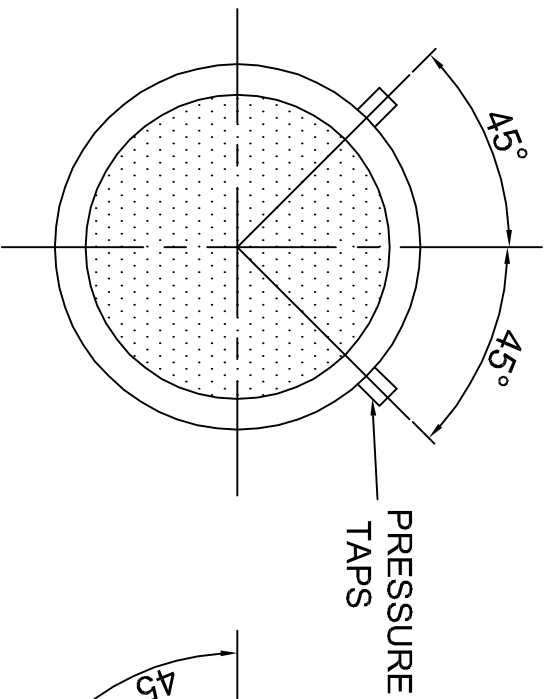

LIQUID

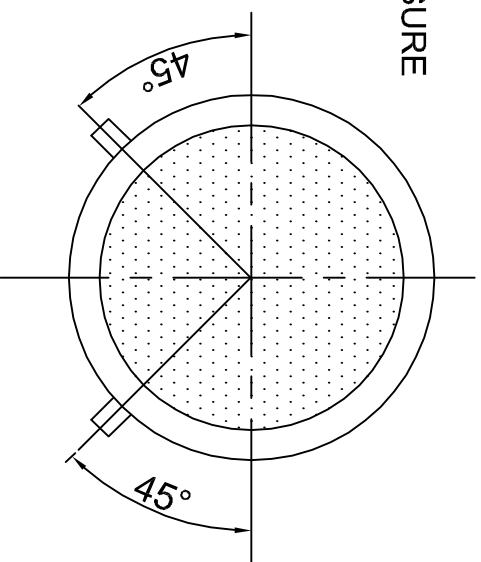

STEAM

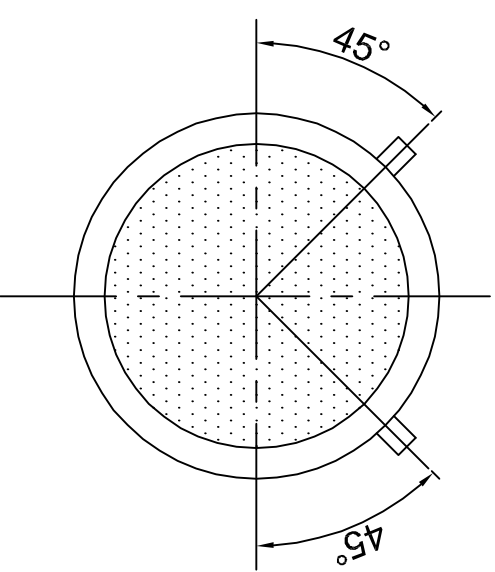

PROCESS PIPING

PROCESS PRESSURE TAP ANGLE
(FOR HORIZONTAL PIPING)



DELTA ENGINEERING
10 Krishnakunj, 1187/23 Ghole Road, Shivajinagar, Pune 411005

HORIZONTAL PROCESS PIPE

VERTICAL PROCESS PIPE

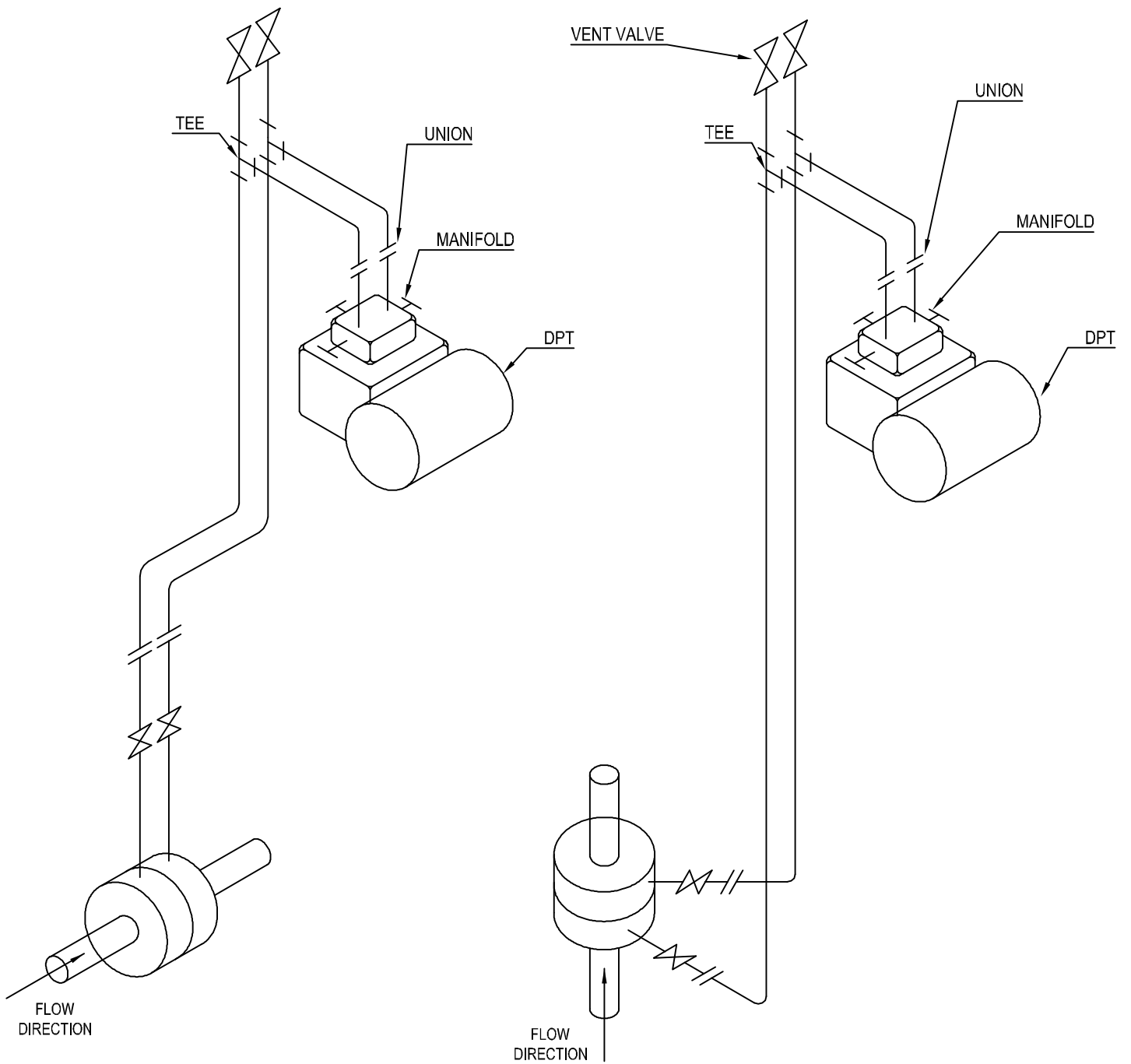

IMPULSE PIPING FOR GAS FLOW MEASUREMENT (ORIFICE, NOZZLE, VENTURI)



DELTA ENGINEERING

10 Krishnakunj, 1187/23 Ghole Road, Shivajinagar, Pune 411005

HORIZONTAL PROCESS PIPE

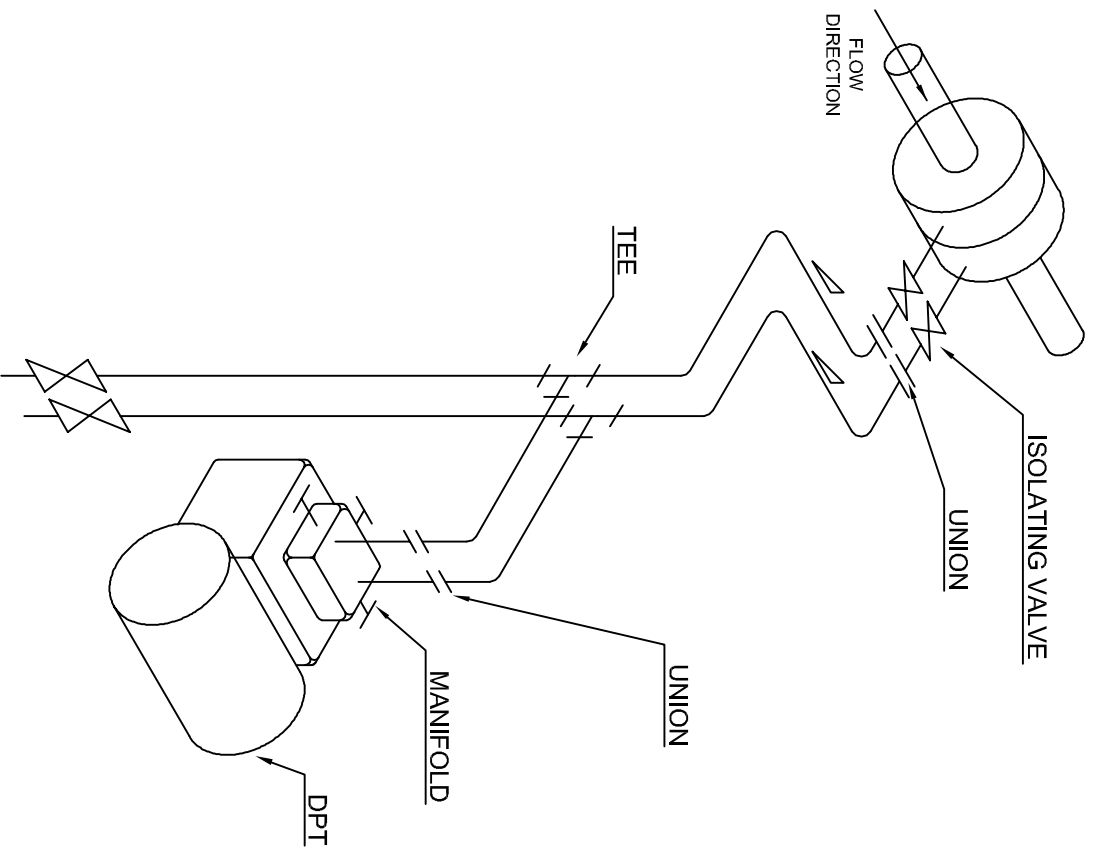

VERTICAL PROCESS PIPE

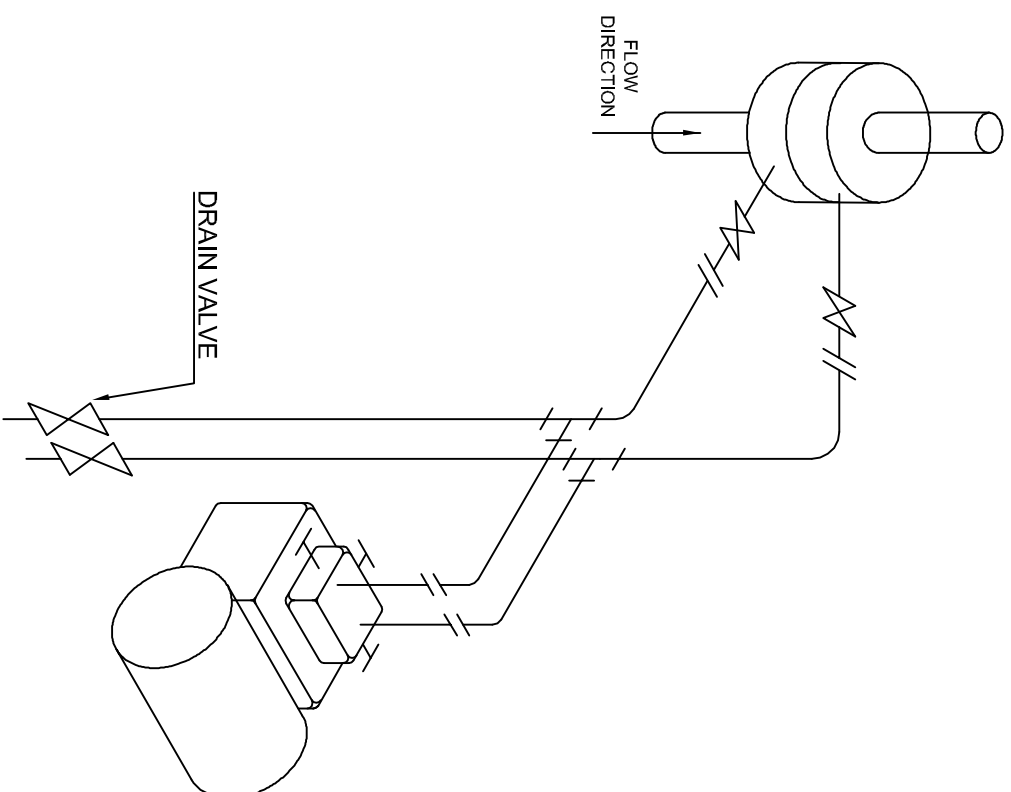

IMPULSE PIPING FOR LIQUID FLOW
MEASUREMENT (ORIFICE, NOZZLE, VENTURI)



DELTA ENGINEERING
10 Krishnakunj, 1187/23 Ghole Road, Shivajinagar, Pune 411005

HORIZONTAL PROCESS PIPE

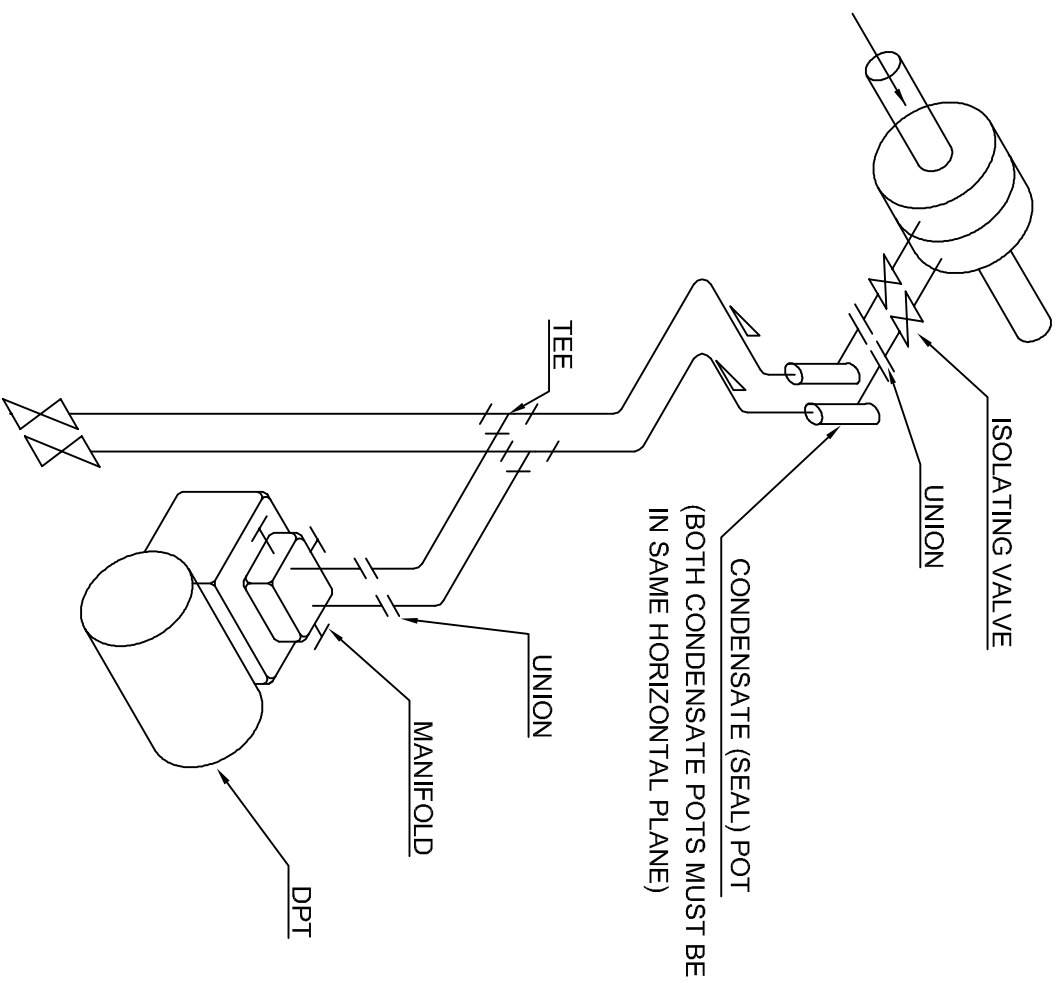

VERTICAL PROCESS PIPE

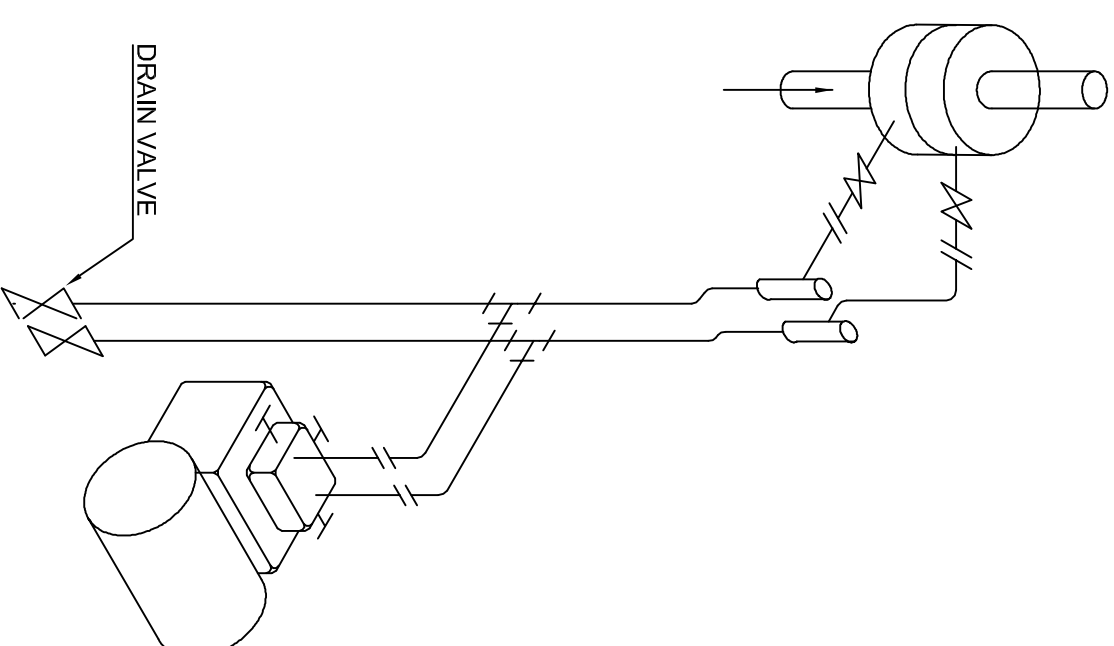

IMPULSE PIPING FOR STEAM FLOW MEASUREMENT (ORIFICE, NOZZLE, VENTURI)



DELTA ENGINEERING
10 Krishnakurji, 1187/23 Ghole Road, Shivajinagar, Pune 411005

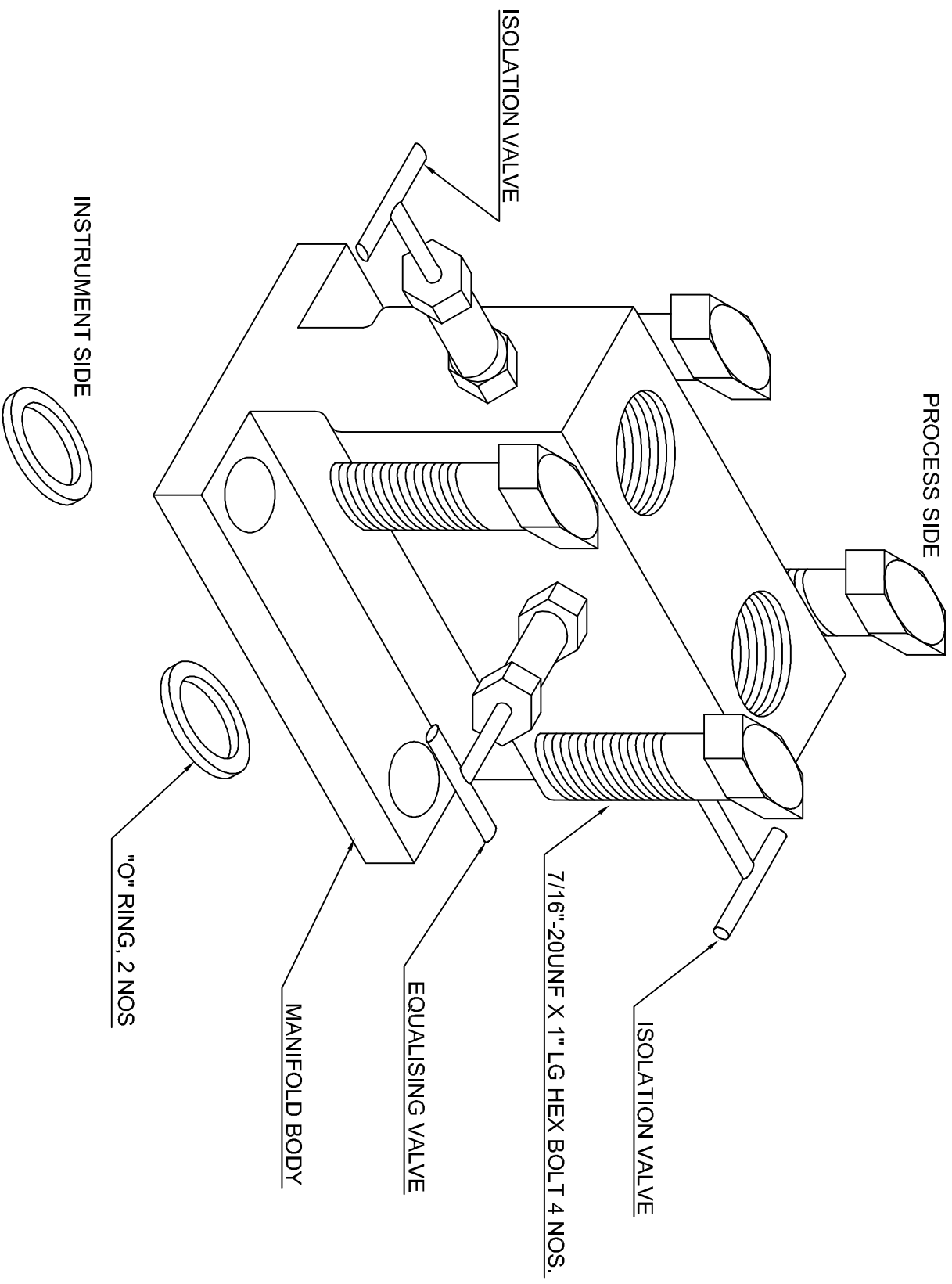

"T" TYPE THREE VALVE MANIFOLD



DELTA ENGINEERING
 10 Krishnakunj, 1187/23 Ghole Road, Shivajinagar, Pune 411005

HORIZONTAL MOUNTING PIPE

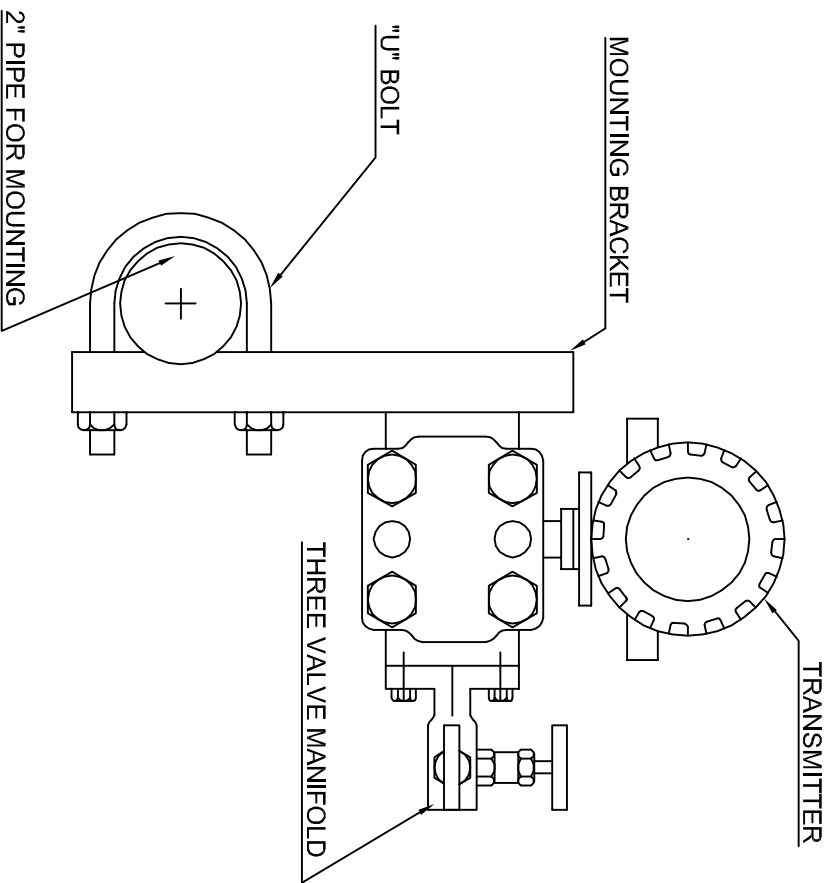

VERTICAL MOUNTING PIPE

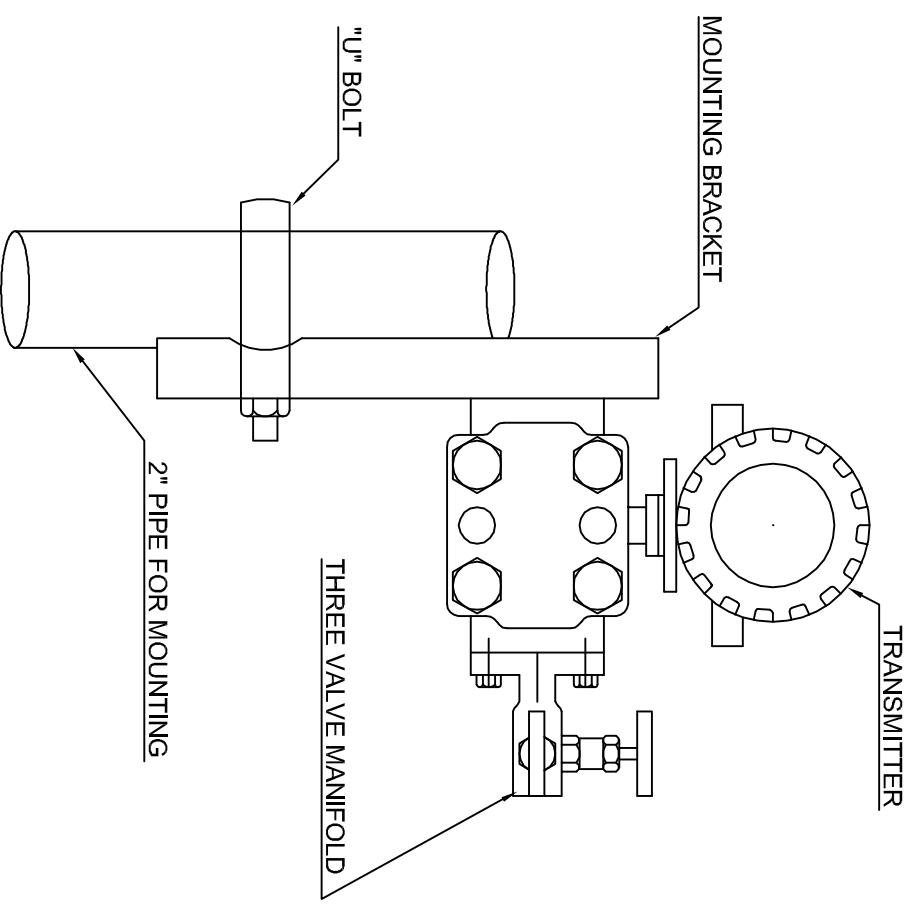

MOUNTING TRANSMITTER ON
VERTICAL OR HORIZONTAL PIPE



DELTA ENGINEERING

10 Krishnakunj, 1187/23 Ghole Road, Shivajinagar, Pune 411005